

AMC

INSTRUCTIONS

**1964-1969 American & Rogue
SUB-FRAME CONNECTORS**

control freak
suspensions™

www.FreakRide.com



Revised 10/2018

Tech Line: 407-696-2772

control freak
suspensions™
www.FreakRide.com

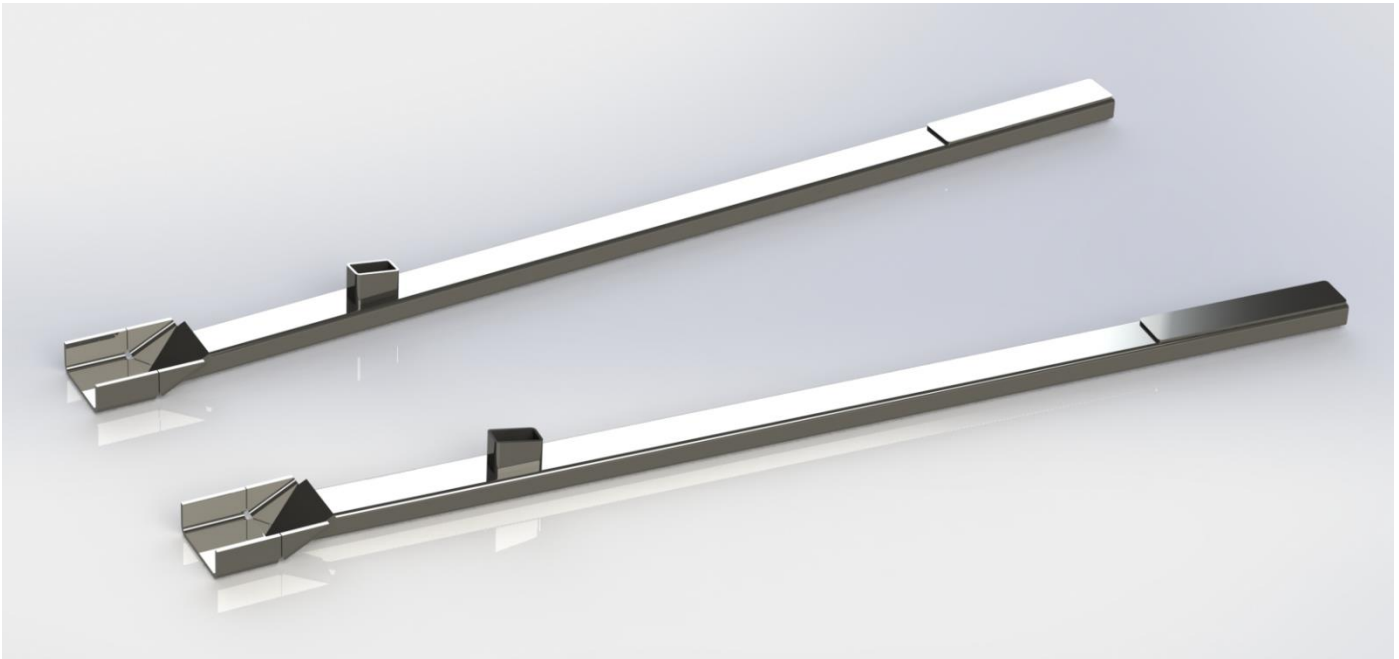

Installation Instructions

Vehicle: 1964-68 American & 1966-69 Rogue
Sub-Frame Connectors

Sub-Frame System Contents

- Two (2) pre-cut 1" x 2" x .125 wall rectangular tube bars
- Two pre-made wedge-shaped brackets for front frame connection
- Two small angle cut 1" x 2" x .125 wall rectangular tubes
- Two 1/8" x 2" x 8.75" Shims

Thank you for purchasing a world-class Control Freak Suspensions® Rambler American/Rogue sub-frame connector kit manufactured in Sanford, Florida. We believe this system is the best available at any price. As with any aftermarket performance product, this system is recommended for off road use only. This system is typically subjected to uses that exceed its mechanical limits, so there is no warranty, expressed or implied. Blue Moon Services LLC and its Control Freak Suspensions brand cannot control how this product is installed or used. By purchasing this product, you are assuming all risks associated with its installation and use and agree to possess appropriate skills for its installation and use. Blue Moon Services LLC and its Control Freak Suspensions brand, our vendors and suppliers will not be held responsible, liable or accountable for any injury, damage, loss, penalties or fines that occur, directly or indirectly, from the installation and use of this product.

Please note that while installation is relatively easy for those with welding skills and moderate experience, novices should employ a professional for installation. Fit is guaranteed on vehicles that are unmolested...that is cars that have not suffered any chassis or significant sub-frame damage. Such damage can bend or alter the unitized body or chassis, making installation more difficult and may require chassis adjustment.

Read all of the instructions before starting installation.

IMPORTANT NOTES:

1. Installation of the sub-frame connectors is relatively easy but welding is required.
2. Use extra caution in jacking and stabilizing the vehicle for this installation. A lift is highly recommended.

What Else Do I Need?

Everything you need is included in the purchase price. Installation requires welding and we recommend MIG welding for strength and looks. Disconnect your battery BEFORE welding. If you don't you run the risk of ruining electronic ignition and entertainment components in the car.

If you plan on installing the Control Freak Suspension 4-link coil over rear suspension system for this vehicle, now is the time to do so, before welding the sub-frame connector bars into place.

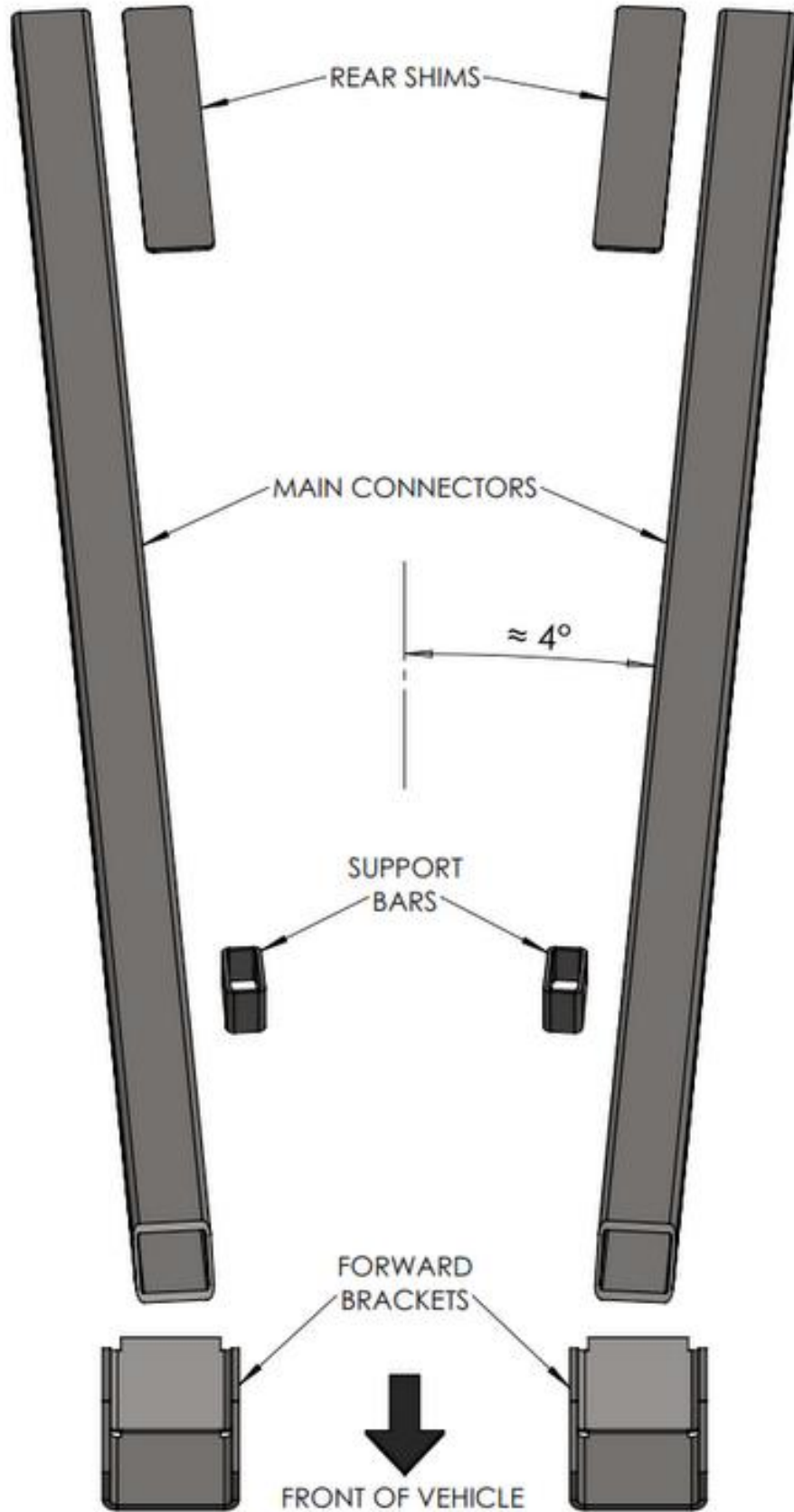

Tech Line: 407-696-2772

control freak
suspensions™

www.FreakRide.com

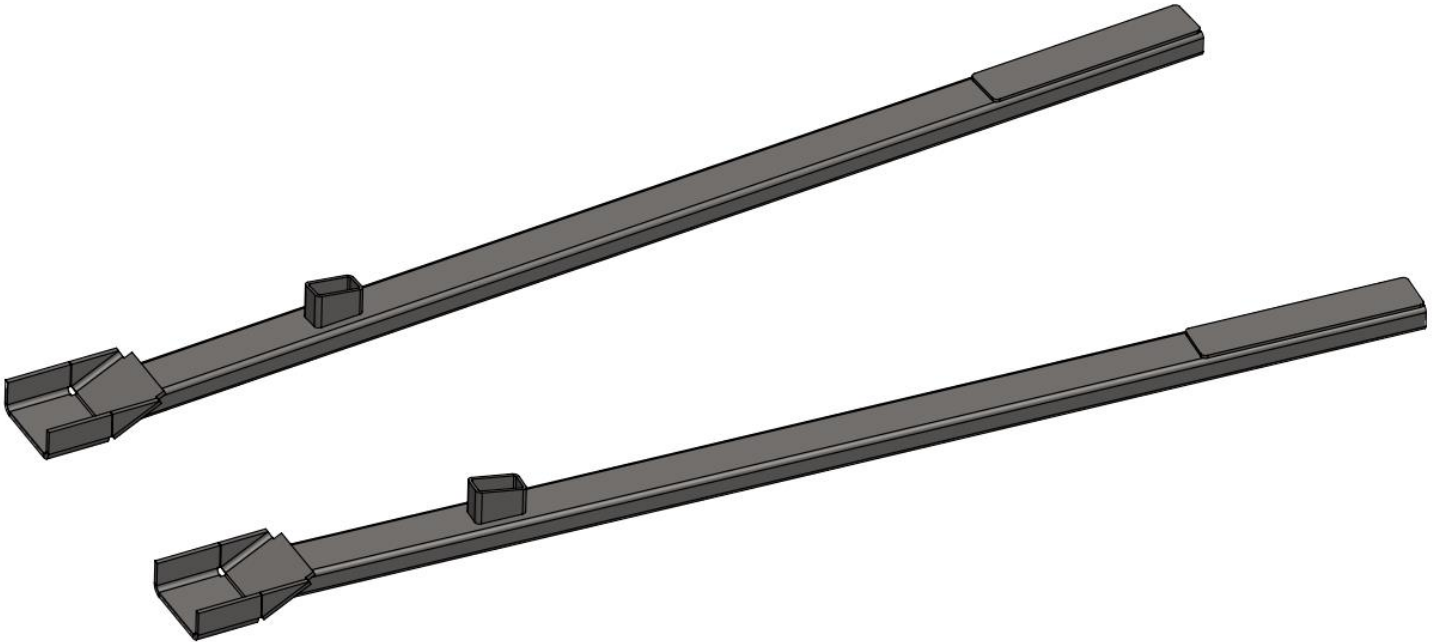

Installation

1. Now is the perfect time to clean up the vehicle underside of debris, oil or other unsightly elements.
2. You will need to sand all debris away from where the brackets will be welded on the sub-frames, front and rear. Also sand the area where the sub-frames come in contact with the rear floor pans.
3. Put the car securely on large jack stands or on a lift. A lift is preferred for ease of installation and safety. Do not compromise safety for expedience.
4. Place the wedge-shaped bracket onto the rear of the front sub-frame. Once flush into position, tack weld the front edge and the sides. Small tack welds are desirable because if you need to make a change, small tacks are easier to cut.



5. Place the long bars into position on the appropriate sides of the vehicle. Angle cuts on the front determine the correct side of the vehicle. On the left (driver) side of the vehicle, the parking brake cable and a fuel /brake line may need to be moved slightly to clear the bars. Do this carefully.
6. We have added a about an inch of extra material on the rear of the bars, just in case you wish to have a longer weld. Be certain to insert the thin shim between the rear sub-frame bar and the rear chassis.

NOTE: REMOVE INTERIOR CARPET AND INSULATION BEFORE WELDING. YOU WILL BE WELDING TO THE FLOOR PANS WHICH COULD CAUSE A FIRE.

7. When the long bars have been tack welded into position, insert the small wedge-shaped bars as show in the picture. Make certain they meet the stamped bracket on the underside of the vehicle. Depending on the condition of your floor pans, some of the wedge-shaped part will need to be trimmed. Do not force it into position. Trim it so it slides in easily as it will be welded into position on the sub-frame connector and the floor brace. Tack weld into position.



8. When all parts have been tack welded into position, you are ready to begin the final welding. Weld in small sections at a time, allowing one area to cool while welding another section.
9. First weld the brackets to the sub -frame and then the long bars to the front brackets and rear sub-frame.

10. Once cooled, weld the small wedge-shaped piece to the bars and the floor pans as shown in the picture below. They will install in the center of the long bars and match up to a stamped steel bracket running across the floor pans.



11. Finally, put small stitch welds along both sides of the sub-frame connectors where they meet the floor pans. Do a little at a time, moving to another area allowing the previously welded area to cool.
12. Once welded, the sub-frame connectors are correctly installed and you're ready to drive your vehicle.

IMPORTANT

DISCLAIMER In an effort to offer our customers value and service, Blue Moon Services LLC d/b/a Control Freak Suspensions (herein referred to as Control Freak) reserves the right to change suppliers, specifications, colors, prices, materials. Each of the previous items is subject to change without notice. Control Freak is not responsible for any typographical errors or misinterpretations. Quantities are limited on some items.

WARRANTY DISCLAIMER The purchaser understands and recognizes that racing parts, specialized high performance equipment, and all parts and services sold by Control Freak, are exposed to many and varied conditions due to the manner in which they are installed and used. Control Freak makes no warranties, either expressed or implied, including any warranty of merchantability or fitness for a particular purpose other than those contained in its current catalog with respect to the goods identified on the face of the invoice. There is no warranty expressed or implied as to whether the goods sold hereby will protect purchaser or ultimate user of such goods from injury or death. Control Freak assumes no liability for these suspension products.

DAMAGE CLAIMS Always inspect your package upon delivery. Inspect all packages in the presence of the delivery driver. The driver must note any damage. Ask the driver the Carrier's procedures for handling damage claims. You must hold the original box, packing material and damaged merchandise for inspection or the carrier will not honor the claim. Notify Control Freak for instructions on returning damaged goods. Control Freak is not responsible if no notification is given within two (2) days of receipt.

SHORTAGES Always check the contents of your delivery to insure all the parts that you ordered were received. Please read the invoice and Pack Lists. Double check all packing materials, small items may be wrapped inside with these products. Shortages may occur from damage to the box, so save all packing materials. Inspect the box for holes that would allow parts to fall out. If you are missing any item(s) be sure to check your invoice and/or Pack List for back orders or canceled items before calling the customer service department. If Control Freak has to split a shipment into multiple boxes, packages may be delivered on different days. You need to contact the customer service department within 5 days of delivery to assure the prompt replacement. Control Freak assumes no liability after this period.

WARRANTY CLAIMS If an item has a manufacturer's warranty as being free from defects we will exchange that item. If the item has been used and you are requesting warranty work, Control Freak will determine the validity of the claim. If you have any questions, please contact customer service.

RETURNS Our return policy applies to all suspension systems **except** Independent Front Suspension (IFS) systems. Control Freak wants you to be satisfied with your purchase. If within five (5) days after you receive your shipment you are not satisfied, you may return the item for refund, exchange or credit. **This does not apply to any IFS systems.** All exchanged or returned merchandise must be in original factory condition with no modifications or alterations. Returned merchandise must include all original packaging materials, warranty cards, manuals, and accessories. If the items being returned need to be repackaged there will be a re-packing charge of 15%. Pack the item in a sturdy box and include a copy of your invoice and notify us of the return. You must ship orders back **PRE-PAID. WE DO NOT ACCEPT COD SHIPMENTS.** All exchanges need to have reshipping charges included. Items that are returned after 5 days are subject to 15% restocking charges. **Absolutely no returns on custom built suspension systems or other special-order merchandise. All IFS systems are considered custom builds. All exchange and/or repair is at the discretion of Control Freak Suspensions.**

Some items may not be street legal in some countries. Such items may be legal for racing vehicles only which may not be used upon a highway

Tech Line: 407-696-2772



NOTES:

Check Out Our Other AMC Suspension and Go-Fast Goodies



Coil-Over Conversion Kits – 1970 & up

AMX, Javelin, Spirit, Hornet, Gremlin, Rebel, Rebel Machine, Matador, Concord & Bricklin



4-Link Coil-Over Rear Suspension Kits

AMX, Javelin, Rebel, Ambassador, American, Spirit, Hornet, Gremlin & Concord

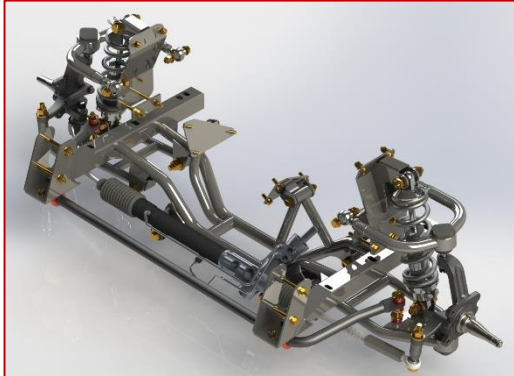

Independent Front Suspension Systems

AMX, Javelin, Rebel, Ambassador, American, Spirit, Hornet, Gremlin & Concord

Brake Systems From Wilwood



Add Performance, Handling & Safety
to Your AMC. Ask About Our:

- *Sub-Frame Connectors*
- *Sway Bar Kits*
- *Flaming River Columns*

AMC

INSTRUCTIONS

AMERICAN SUB-FRAME CONNECTORS

control freak
*suspensions*TM

www.FreakRide.com

control freak
*suspensions*TM

www.FreakRide.com

Control Freak Suspensions

2920 W. Airport Blvd., Suite 110

Sanford, FL 32771

407-696-2772

www.FreakRide.com